

2265 Crosswind Drive • Prescott, AZ 86301
(928) 636-3175 • www.p-a-g.net

FORD F250, F350 SUPER DUTY (ORIGINAL EQUIPMENT REPLACEMENT) STEERING STABILIZER INSTALLATION INSTRUCTIONS 1999-2000 **SS KIT# 6102** **SSV KIT# 7102**

⚠ WARNING

Before you install this kit, read and understand all instructions, warnings, cautions, and notes in this instruction sheet and in the vehicle owner's manual.

⚠ CAUTION

Proper installation of this kit requires knowledge of the factory recommended procedures for removal and installation of original equipment components. We recommend that the factory shop manual and any special tools needed to service your vehicle be on hand during the installation. Installation of this kit without proper knowledge of the factory recommended procedures may affect the performance of these components and the safety of the vehicle. We strongly recommend that a certified mechanic familiar with the installation of similar components install this kit.

⚠ WARNING

This kit should only be installed on a vehicle that is in good working condition. Before you install the kit, thoroughly inspect the vehicle for corrosion or deformation of the sheet metal. If the vehicle is suspected to have been in a collision or misused, do not install this kit. Off-road use of your vehicle with this kit installed may increase the stress applied to the factory components. Failure to observe this warning may result in serious personal injury and/or severe damage to your vehicle.

⚠ WARNING

Always wear eye protection when operating power tools.

⚠ WARNING

Before you install this kit, block the vehicle tires to prevent the vehicle from rolling.

NOTE

Performance Automotive Group recommends using the Loctite® supplied in the kit on the threads of all kit nuts and bolts unless specified otherwise in these instructions.

Before Starting Installation

NOTE

Kit parts are prefaced by the word *kit* and appear in **bold** print.

1. Carefully read all warnings and instructions completely before beginning.
2. Verify all parts have been received in this kit by checking the parts list at the end of this document.
3. **Only install this kit on the vehicle for which it is specified.** If anytime during the installation you encounter something different from what is outlined in the instructions, call technical support at (928) 636-3175.
4. Park vehicle on a clean, dry, flat, level surface and block tires so vehicle cannot roll in either direction.

NOTE

Adhere to recommendations when replacement fasteners, retainers and keepers are called out in the factory service manual. When re-assembling the vehicle it is recommended by the vehicle manufacturer that certain fasteners are replaced in order to maintain proper retention characteristics. This system may not include all replacement hardware as recommended by the factory service manual. Additional replacement hardware should be obtained prior to installation of this system to meet the requirements of the factory service manual.

Torque Specifications

See factory service manual for torque values when re-using OE fasteners.

Bolt Size	Grade 5 (ft.-lbs.)	Grade 8 (ft.-lbs.)
1/4"-20	10	10
1/4"-28	10	12.5
5/16"-18	17	22.5
5/16"-24	20	25
3/8"-16	30	40
3/8"-24	35	45
7/16"-14	50	65
7/16"-20	55	70
1/2"-13	75	100
1/2"-20	55	70
9/16"-12	105	135
9/16"-18	115	150
5/8"-11	150	195
5/8"-18	160	210
3/4"-16	175	225

Engine Compartment

1. Disconnect both battery cables. Disconnect negative cable first, then positive cable.

Prepare to Install Steering Stabilizer

1. Set steering wheel and front wheels straight ahead.
2. Remove hardware and OE steering stabilizer from drag link bracket and axle.

Install Steering Stabilizer

1. **From SHBAG78:** Install four *kit bushings* into body and piston end of *kit stabilizer*.

2. **From 6102BAG:** Install two *kit sleeves* (.62" x 1.480") into ends of *kit stabilizer*.

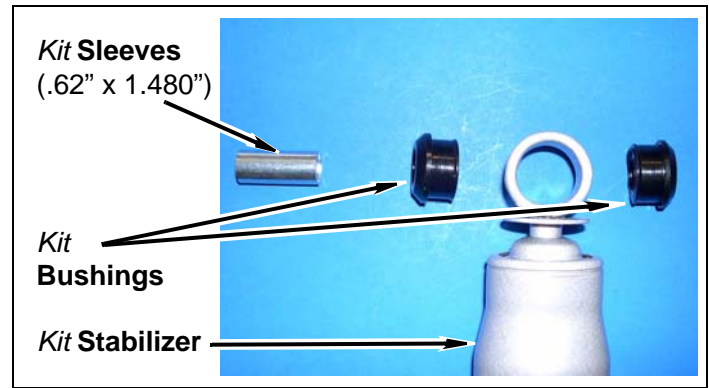

3. Install *kit boot* onto *kit stabilizer* with *kit tie*.

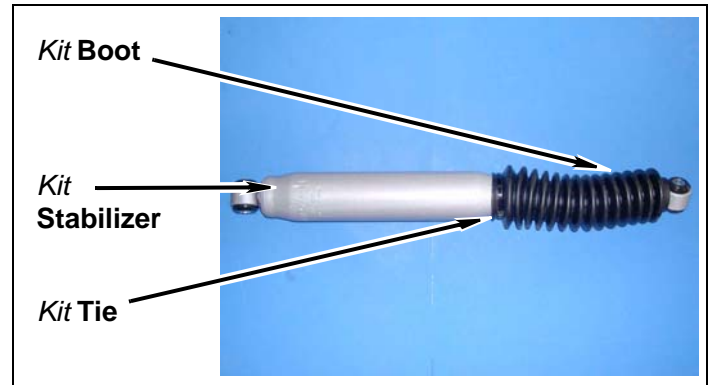

4. **From 6102BAG:** Install body end of *kit stabilizer* onto drag link bracket with *kit bolt* (12mm x 90mm), three *kit washers* (7/16" USS), *kit sleeve* (.750" OD), and *kit nut* (12mm stover). **DO NOT TIGHTEN.**

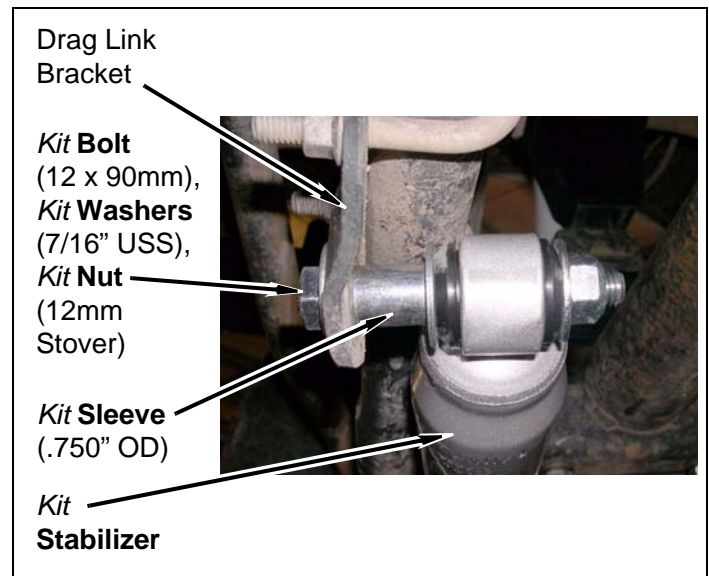

5. Install piston end of *kit stabilizer* onto axle with OE bolt and nut. TIGHTEN OE bolt and nut.

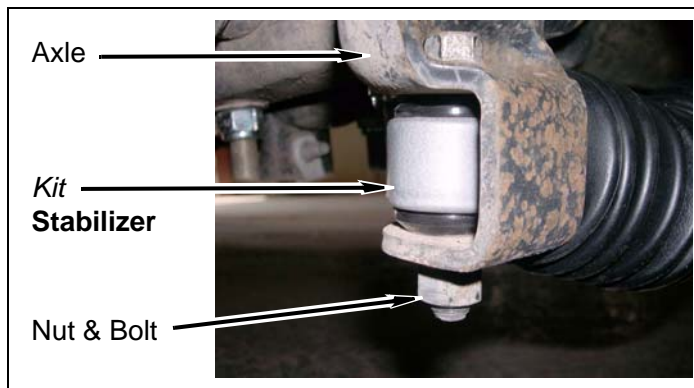

6. TIGHTEN *kit bolt* (12mm x 90mm).

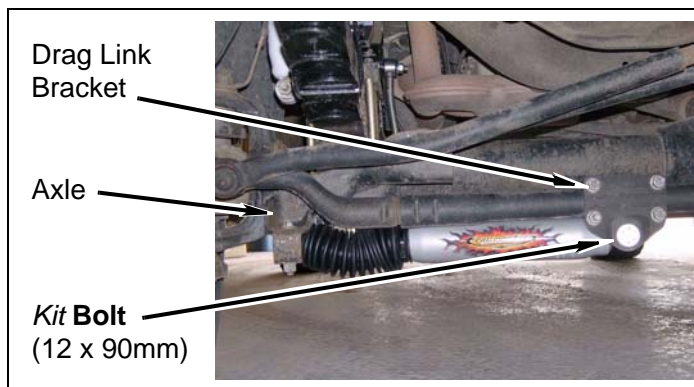

transfer case. Ensure there is full engagement in all gears and 4WD ranges. Check battery connections and electrical component operations. Test-drive vehicle.

⚠WARNING

Retorque all fasteners after 500 miles and after off road use. All suspension lift components should be visually inspected and fasteners retorqued during routine vehicle servicing.

⚠CAUTION

Performance Automotive Group does not recommend any particular wheel and tire combinations for use with its suspension lifts and cannot assume responsibility for the customer's choice of wheels and tires. Refer to your owner's manual for recommended tire sizes and warnings related to the use of oversized tires. Larger wheel and tire combinations increase stress and wear on steering and suspension components, which leads to increased maintenance and higher risk for component failure. Larger wheel and tire combinations also alter speedometer calibration, braking effectiveness, center of gravity, and handling characteristics. Consult an experienced local off road shop to find what wheel and tire combinations work best with your vehicle.

NOTE

All warranty information, instruction sheets, and other documents regarding the installation of this product must be retained by the vehicle owner. Information contained in the instructions and on the warranty card will be required for any warranty claims. The vehicle owner needs to understand the modifications made to the vehicle and how they affect vehicle handling and performance. Failure to provide the customer with this information can result in damage to the vehicle and severe personal injury.

After Completing Installation

Engine Compartment

1. Connect both battery cables. Connect positive cable first, then negative cable.

Miscellaneous

1. Check all fasteners to ensure they are tight.
2. Ensure all wires, hoses, cables, etc. are properly connected and there is ample slack.
3. Turn steering wheel from lock to lock ensuring no bind or interference with *kit stabilizer*.

Dynamic Vehicle Check

1. Check steering and suspension in all positions to ensure that there is no bind and adequate clearance between all moving, fixed, and heated members. Check operation of clutch, brake system, and parking brake. Check operation of transmission and

Kit Parts List

Qty. Description

1	Boot
1	Label (logo)
1	Stabilizer
1	Tie
1	<u>6102BAG (Hardware Bag Kit)</u>
1	Bolt (12mm x 90mm)
1	Nut (12mm stover)
1	Sleeve (.750" OD)
2	Sleeve (.62" x 1.480")
3	Washer (7/16" USS)
2	<u>SHBAG78 (Bushing Bag Kit)</u>
2	Bushing

NOTE

Depending on the vehicle configuration some parts may not be used.